

Z_CAL 150

300



MODE D'EMPLOI
INSTRUCTIONS FOR USE
GEBRAUCHSANLEITUNG



sylvac

Sylvac SA
Ch. du Cloalet 16
CH - 1023 CRISSIER
e-mail : sales@sylvac.ch
Web site : www.sylvac.ch

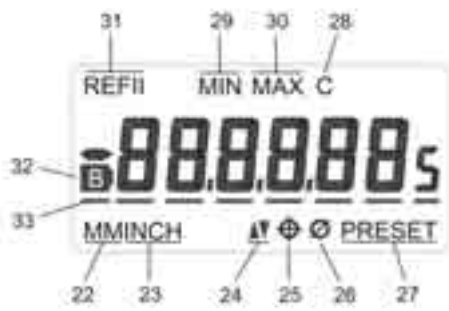
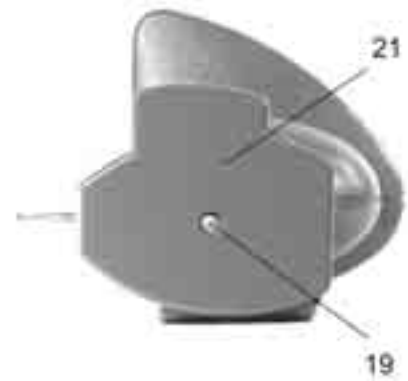
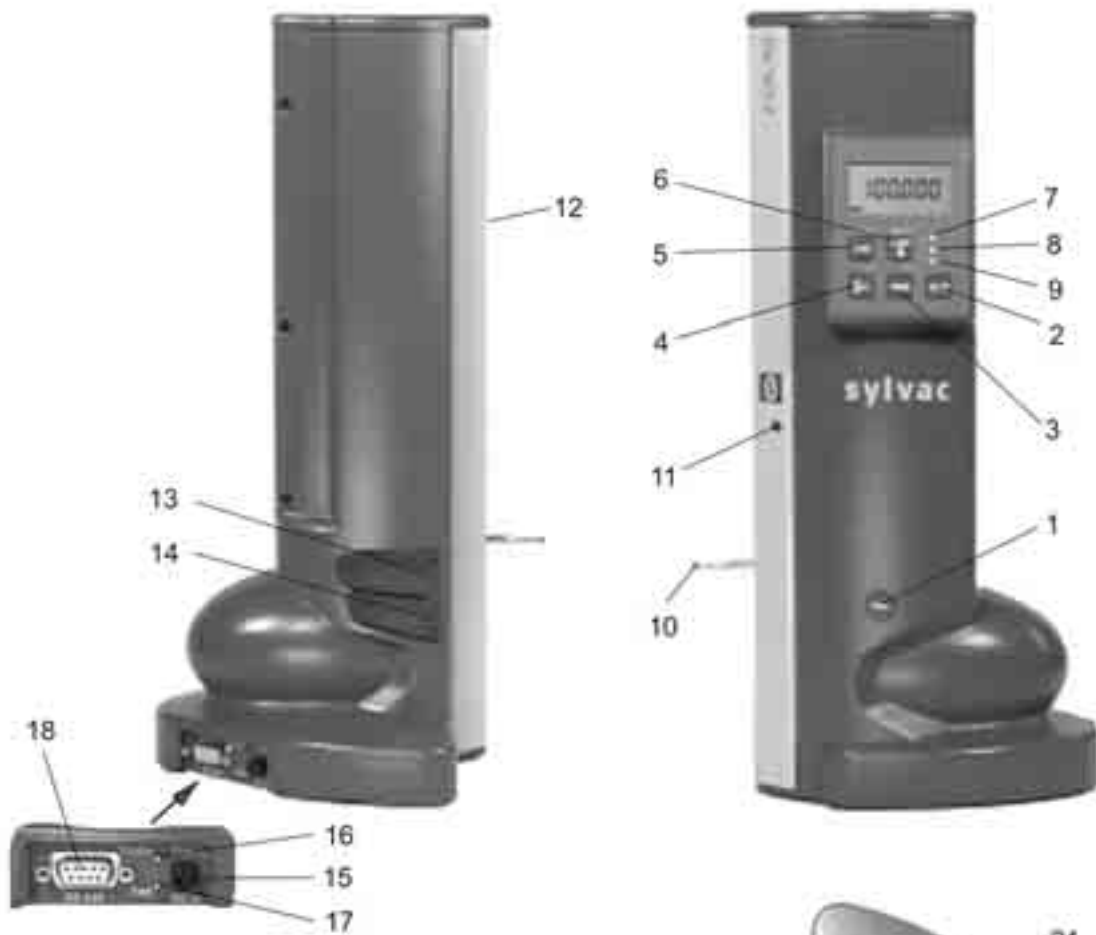

1. DESCRIPTION OF THE INSTRUMENT

- 1 PRINT key (when measuring)
- 2 ON / OFF key
- 3 PRESET key – setting display to zero
- 4 PROBE CONSTANT key
- 5 RESOLUTION key
- 6 NORMAL or DIAMETER / CENTERLINE mode ($\varnothing \oplus$) key
- 7 Green light = normal measurement
- 8 Orange light = measuring diameters
- 9 Yellow light = measuring centerlines
- 10 Probe
- 11 Opening for changing the probe holder
- 12 Nose (yellow section)
- 13 UP key, with *gradual* action
- 14 DOWN key, with *gradual* action
- 15 Connector for AC adapter or data transmission foot pedal
- 16 Green light : indicates the trickle charge with charger connected
- 17 Red light : indicates fast charging
- 18 RS232 connector
- 19 Cover screw
- 20 Counterweight locking screw for shipping
- 21 Top cover

2. DISPLAY FUNCTIONS

- 22 Display in metric mode
- 23 Display in inch mode
- 24 Measuring direction display
- 25 Displayed value = shaft or bore centerline
- 26 Displayed value = shaft or bore diameter
- 27 PRESET mode indicator
- 28 - Displays the value of the probe constant
- Indicates that the keyboard is locked
- 29 Minimum mode active
- 30 Maximum mode active
- 29, 30 TIR mode active = Maximum - Minimum
- 31 Reference 2 active
- 32 Battery life warning display - connect charger
- 33 Cursor for introducing the PRESET

| CONTENTS | Page |
|---|-------------|
| 1. Description of the instrument | 15 |
| 2. Display functions | 15 |
| 3. Introduction | 17 |
| 4. Getting started | 17 |
| 5. How to start up | 18 |
| 5.1 Measuring heights | 18 |
| 5.2 Measuring reverse surfaces - Measuring the probe constant | 18 |
| 5.3 Measuring diameters and centerlines | 19 |
| 6. Main functions | 20 |
| 7. Secondary functions | 21 |
| 8. AC adapter, external contact | 22 |
| 9. RS232 connector | 22 |
| 10. Change of the probe holder | 24 |
| 11. Adjusting the measuring force | 24 |
| 12. Replacing the batteries | 24 |
| 13. Technical specifications | 25 |
| 14. Standard package | 25 |
| 15. Accessories | 26 |

3. INTRODUCTION

The Z_CAL height gauge is designed to work on a flat reference surface, such as granite or scraped cast iron plate... A number of technological innovations make this instrument very suitable for fast, accurate and reliable measurements. It offers the following main advantages :

- Very low measuring force (30 grams) for delicate parts and excellent repeatability.
- Fully motorized probe. Its displacement speed is proportional to the finger pressure. The probe automatically tracks profiles and maintains a constant measuring force : measuring diameters is, therefore, quick and precise.
- Reduced weight, for easy handling.
- Very easy to operate, so that it can be used both in the workshop and laboratory.

4. GETTING STARTED

Unscrew screw (19) and remove cover (21).

Unscrew and remove the M4 x 30 mm screw (20) which secures the counterweight during shipping. **Remove the locking insert** and place the screw it in the provided thread bore.

| |
|---|
| <p>Important : The insert as well as the screw must be replaced for subsequent shipping of the instrument, for inspection or overhaul, as part of after-sales service.</p> |
|---|

Note : the locking of the counter weight is done with the probe down. Remove the probe holder for transport.

Connect the AC adapter (15) :
- **red** light = fast charging 4 hours
- **green** light = trickle charge

Note : charging continuously will not affect the batteries. If the batteries are completely down, the Z_CAL may start searching for its references, moving first to the upper stop (Ref 1) and then to the bottom stop (Ref 0).

Press ON (2) to start up the Z_CAL.

Press up (13) to the upper stop. Introduce the probe holder in the provided location, when pushing up.

Press UP (13) or DOWN (14). The speed is proportional to the pressure applied to these sensitive keys.

5. HOW TO START UP

5.1 MEASURING HEIGHTS



The **green** light comes on when the probe comes into contact with the part being measured.

1. Taking the reference : drive the probe to the reference plane, the green light comes on when the probe touches it. Briefly press the PRESET key (3) to zero the display or to recall the memorized Preset value.
2. Measuring: press the UP key (13) and then the DOWN key (14) and probe another surface. The green light will come on and the height will be displayed.

To display this height to 0.01 mm instead of 0.001 mm, press the RESOL key (5).
To convert to inches, press this same key (5) for a little longer (2 seconds)

5.2 MEASURING REVERSED SURFACES - MEASURING THE PROBE CONSTANT

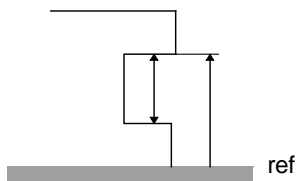

When measuring reversed surfaces, the Z_CAL takes account of the probe constant, i.e. the diameter of the ball probe and its deflection.

The master gauge supplied with the Z_CAL must be used to measure the probe constant (ref. see § 15. Accessories) :

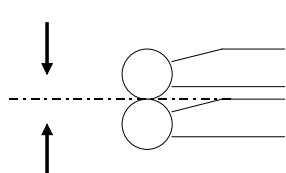

Press key (4) and touch one of the ground surfaces of the cylindrical gauge. Release the probe and touch the opposite surface. The probe constant value is displayed and then memorized following release (it is kept in the memory until it is replaced by a new value).

The constant must be retaken after changing probe or after modifying the probe's position.

Reversed faces may now be measured by pressing the UP key (13) and by touching a reversed surface with the probe : the green light comes on and the height is displayed.

Comment : Once the constant is memorized, both normal and reversed surfaces can be measured, indiscriminately.

5.3 MEASURING DIAMETERS AND CENTERLINES

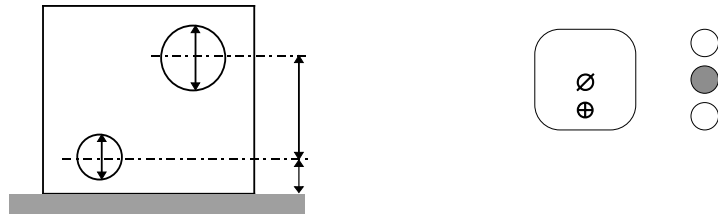

The probe constant value should already have been entered : see § 5.2.

Go to DIAMETER/CENTERLINE mode by pressing the Normal $\emptyset \oplus$ key (6). The orange light (8) will start flashing.

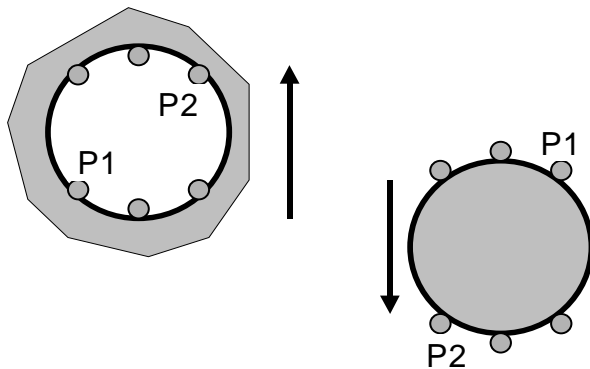

1. Place the probe inside the bore or onto one side of the shaft to be measured and touch a point P1 which is well away from the summit of the curve.
2. Move the part or the Z_CAL sideways to the probe. The minimum/maximum point is memorized.
3. Touch again in P2, and move until the display is steady. The measured diameter is displayed together with the \emptyset symbol of the display (the orange light remains lit).
4. Displaying the centerline can be done in 2 ways:
 - by releasing the probe from the surface.
 - by pressing the Normal $\emptyset \oplus$ key.

The yellow light appears and the centerline is displayed, together with the \oplus symbol of the display.

To measure from this centerline (as a reference), press the PRESET key : the display goes to zero or to the memorized preset value.

Comment : The procedure is the same for shafts or bores (internal or external diameters) and starting can either be from the top or bottom.

Touching again the probe restarts diameter measurement (sequence 1-4).

To change from DIAMETER to NORMAL mode, press the Normal $\emptyset \oplus$ key.

6. MAIN FUNCTIONS

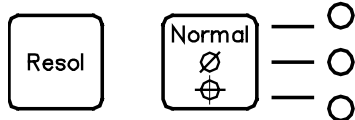

Briefly pressing these keys provides direct access to each function.

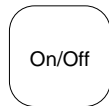
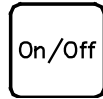
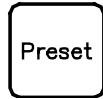
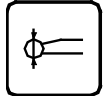

Switches the instrument ON or OFF.



Zeroes the display or sets to the memorized value.

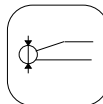

- Displays the probe constant value. Return to measuring mode without change : press any key.
- Measuring the constant : one measurement on each side of the master gauge (see 5.2).



- **Normal** = green light = measuring heights of normal and reversed surfaces (the probe constant must have been previously entered to measure reversed surfaces).
- ∅ = orange light = measuring diameter (takes account of probe constant). Measures internal or external diameters in any sequences.
- ⊕ = yellow light = displays the centerline. Comes after the diameter display, as soon as :
 - the probe is released, or
 - the Normal ∅ ⊕ key is pressed

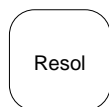

Changes the display resolution:
0.001 mm ↔ 0.01 mm.
or :
0.00005 in ↔ 0.0005 in.

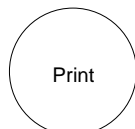

RS232 data output (function 1), *only when measuring*. If Print or the external contact is held when switching on : changes Print or external contact function :

- 1 = Print = RS232 data output
- 2 = Zero setting of the display
- 3 = Switches between Normal ↔ Diameter mode
- 4 = Switches between references Ref 1 ↔ Ref 2

Choice of function by pressing Print or the external contact, validation by pressing any other key

7. SECONDARY FUNCTIONS

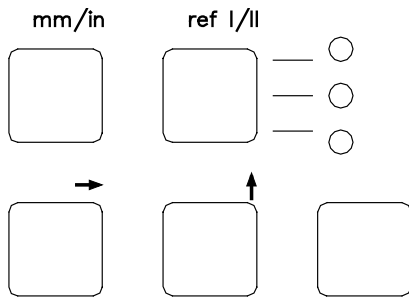

Access by long pressure on the keys

mm/in : Direct conversion of mm ↔ inches.
To lock or unlock the conversion: switch the instrument on while pressing the Resol key.

Ref I/II : Change of reference. For example:
- Reference 1 with Preset = 0.000 mm
- Reference 2 with Preset = 100.000 mm

↑ : Introducing a Preset value:
→ to go from one digit to the next
↑ to increment the digit
Confirm the value introduced by prolonged pressing on → or by pressing one of the top 2 keys (Resol or Normal $\emptyset \oplus$).

→ : Modes:
Normal → Minimum → Maximum → Maximum-minimum



Reinitialisation in min/max mode via the Constant or Print key.

8. AC ADAPTER, EXTERNAL CONTACT

B If the indicator (32) showing complete battery discharge is displayed, connect the AC adapter. The instrument remains operational. Complete recharging takes 4 hours. A foot pedal may be connected to the external contact (15) for data transfer. Another function may be assigned to it (see § 6, Print key).

9. RS232 CONNECTOR

The RS232-C port (18) is **OptoRS compatible** (see OptoRS convention for more informations). It allows connection to a printer to protocol the measurement results or to a computer. The latter may remotely control all the instrument functions as well as provide the possibility to position the probe.

Female 9 pins D-Sub connector (seen from the outside):

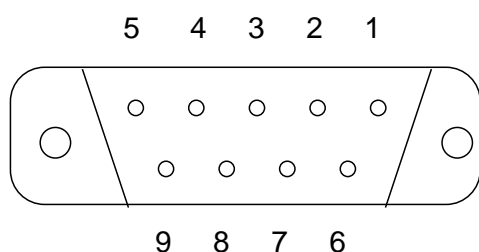

Pin 1 : +9 V output if charger connected
or +9 V input from external supply
Pin 2 : **RXD** = RS232 output of the Z_CAL
Pin 3 : **TXD** = RS232 input from the PC
Pin 5 : **SG** = signal ground

Data transmission format: : **4800 bps, 7 bits, even parity and 1 stop bit.**

The value is sent in ASCII code :

In mm : **SIGN 10² 10¹ 10⁰ DP 10⁻¹ 10⁻² 10⁻³ CR**

Comments : - 10⁻³ only for 0.001 mm resolution
- 10² and 10¹ = spaces if they are zero
- there is no space between minus sign and the first numeral
- the + sign is replaced by a space

In inches : **SIGN 10¹ 10⁰ DP 10⁻¹ 10⁻² 10⁻³ 10⁻⁴ 10⁻⁵ CR**

Comments : - 10⁻⁵ only for 0.00005 inch resolution
- 10¹ = space if zero
- there is no space between minus sign and the first numeral
- the + sign is replaced by a space

Remote control of the Z_CAL :

The instrument functions are controlled externally by an ASCII code corresponding to the 3 first letters of the function. Spaces are removed. The message may be in upper or lower case. The question mark ? implies an instrument response.

| | |
|----------------------|--|
| ? or PRI (PRInt) | requests displayed value |
| CLE (CLEar) | reinitialises the maximum / minimum memories |
| EXT0 | external contact = data transmission |
| EXT1 | external contact = display preset |
| EXT2 | external contact = normal mode ↔ diameter mode |
| EXT3 | external contact = reference mode 1 ↔ reference mode 2 |
| EXT? | asks for current function of external contact |
| (EXTernal contact) | |
| EXTB... | same as above, but for Print key functions |
| ID? (Identification) | Z_CAL replies : SYLVAC Z_CAL |
| IN (Inch) | display unit |
| MM (MilliMeter) | display unit |
| KEY0 (KEYboard) | keyboard locked |
| KEY1 | keyboard unlocked |
| AXI (AXIs) | centerline mode |
| DIA (DIAMeter) | diameter mode |
| DEL (DELta) | maximum - minimum difference mode |
| NOR (NORmal) | normal mode |
| MAX (MAXimum) | maximum mode |
| MIN (MINimum) | minimum mode |
| MOD? (MODE) | interrogation of the measuring mode : NOR,DIA,AXI,MIN,MAX,DEL |
| POS + number | the instrument positions itself to the value transmitted. If an obstacle inhibits movement, positioning is given up. |
| PRE (PREset) | displays the preset value |
| PRE + number | memorises a new preset value |
| PRE? | interrogates the memorised preset value |
| REF1 | reference 1 |
| REF2 | reference 2 |
| RES2 (RESolution) | 0.001 mm - 0.00005 in resolution |
| RES3 | 0.01 mm - 0.0005 in resolution |
| SET? (SETting) | interrogation of general parameters : MM/IN RES2/3 REF1/2 KEY0/1 B0/1. B0 = battery recharging. |
| UNI? (UNIT) | measuring unit : MM or IN |
| UNI1 | mm/inch conversion unlocked |
| UNI0 | mm/inch conversion locked |
| VER? (VERsion) | instrument program version and date |

10. CHANGING THE PROBE HOLDER

To change the probe holder, raise the probe using the UP key (13) to the upper stop. Remove it while pushing it up. Introduce the new probe holder

Turn correctly the eccentric probes. Clamp firmly but do not force, using the 2.5 mm imbus key.

Make sure to keep the same weight (for the part probe + the probe holder) while using other probes : 2 oz \pm 0.5 oz (refer to the indications provided with the set of probe holders).

The probe constant must be measured, see chapter 5.2.

11. ADJUSTING THE MEASURING FORCE

The measuring force is factory set to 1 oz. Only proceed with a change if this is necessary. The force can be adjusted within a range of 0.9 to 1.8 oz. To do this :

1. Remove the cover (21).
2. Remove the nose (12) by sliding it upwards \uparrow in order to gain access to the adjustment orifice.
3. Insert the carriage adjusting screw into the orifice.
4. Turn the screw clockwise to increase the measuring force. Check the latter using the force measuring device (Correx type). *Too low pressure may affect repeatability.* 1 turn = 0.035 oz.
5. Refit the nose and cover.

12. REPLACING THE BATTERIES

As soon as the autonomy of the Z_CAL becomes insufficient, the batteries should be changed (lifespan about 4 to 6 years).

1. Purchase a battery pack from your Sylvac agent.
2. Disconnect the instrument, turn it upside down and lay it on its cover (21).
3. Unscrew the protection plate.
4. Disconnect the battery pack, note the the connector's polarity.
5. Connect the new pack and refit the protection plate.

13. TECHNICAL SPECIFICATIONS

| | Z_CAL 150 | Z_CAL 300 |
|---|---|--------------------|
| Measuring range | 150 mm | 300 mm |
| Total measuring range | 155 mm | 320 mm |
| Resolution | 0.00005 in (1 µm) | |
| Accuracy (precision) [µm] (with standard probe, at 20 ±0.5 °C) | 3 + L [mm] / 150 | 3 + L [mm] / 150 |
| Repeatability | 0.00008 in (2 µm) | |
| Probe max speed | 3 m/s | |
| Motor max speed | 0.1 m/s | |
| Measuring force (set at works) | 0.3 N (1 oz) | |
| Measuring range of measuring force | 0.25 N...0.5 N (0.9 ... 1.8 oz) | |
| Operation time | 40 hours approx. | |
| Space requirement (widthxdepthxheight) | 180 x 150 x 350 mm | 180 x 150 x 520 mm |
| Weight | 8.2 lb (3.7 kg) | 9.7 lb (4.4 kg) |
| Data input/output | RS232, OptoRS compatible | |
| Number of measurements / second | in normal mode : 12 measurements./sec. in diameter/min/max mode : 50/sec. | |
| Supply | Batteries : 4xAA NiMH 1300 mAh | |
| Operating temperature | +10 to + 40 °C | |
| Storage temperature | -20 to + 45 °C | |
| Thermal expansion coefficient | like steel, between +10 and +30 °C : (11.5 ±1.5) x 10 ⁻⁶ [1/°C] | |
| Measuring system | SYLVAC inductiv system, patented | |

14. STANDARD PACKAGE

| | Item Nr. |
|--------------|----------|
| Z_CAL 150 mm | 930.0150 |
| Z_CAL 300 mm | 930.0300 |

with :

- 1 fixed tungsten carbide probe, with sapphire ball Ø 3 mm
- 1 probe holder for standard probes Ø 4 mm
- 1 master gauge
- 1 2.5 mm hexagonal (imbus) spanner, for tightening the probe
- 1 charger 8.5 V (mains voltage according to the country)
- 1 protection cover
- 1 calibration certificate
- 1 instructions manual

15. ACCESSORIES

| | Item No. |
|--|----------|
| - Set No. 1 with special probes in a wooden case comprising : | 930.2151 |
| - 1 probe with sapphire ball , \varnothing 2 mm | |
| - 1 probe, \varnothing 1 mm / M1.4 and tightening spanner | |
| - 1 probe with bevelled anvil in hard metal | |
| - 1 probe with rounded anvil \varnothing 3 x 5 mm to measure threads | |
| Note : all these probes weigh 7 grams and therefore require no rebalancing of the measuring force. | |
| - Set No. 2 with special probes in a wooden case comprising : | 930.2150 |
| - in addition to the above set nr 930.2151 : | |
| - 1 holder, length 80 mm with M2.5 end bit at 90°, weight 9 grams. | |
| - 1 holder, length 80 mm with \varnothing 4 mm nipple, at 90°, weight 9 grams. | |
| - 1 extended holder, length 124 mm M2.5, weight 12 grams. | |
| - 1 extended holder, length 80 mm M2.5, weight 7 grams. | |
| - 1 ball probe \varnothing 2 / M2.5 | |
| - 2 "parasol" key | |
| - 1 key with slewable sapphire ball, weight 4 grams. | |
| - 1 foot key | |
| - 1 Imbus spanner 1.5 mm | |
| - 1 Imbus spanner 2.5 mm | |
| - Set No. 3 with probe holders in a wooden case comprising : | 930.2140 |
| - 1 short horizontal holder | |
| - 1 long horizontal holder | |
| - 1 short vertical holder | |
| - 1 long vertical holder | |
| - 1 stand for holders | |
| - Fixed tungsten carbide probe, with sapphire ball \varnothing 3 mm | 930.2146 |
| - Master gauge for measuring the constant | 930.2001 |
| - Connection cable for PC 9M-9F 3m | 925.5609 |
| - SP1 printer with statistics | 926.1807 |
| - D100S statistics processing unit | 804.1101 |
| - SYLWIN Windows program (3 1/2 " diskette) | 981.7131 |
| - Spare battery pack | 930.2170 |
| - Z_CAL 150 protective cover | 930.0151 |
| - Z_CAL 300 protective cover | 930.0301 |
| - Imbus spanner, 2.5 mm for clamping the probe | 930.2160 |

Modifications reserved

